

Technical Reference

Tektronix

P7313
12.5 GHz 5X/25X
Differential Probe
071-1704-01

Copyright © Tektronix, Inc. All rights reserved. Licensed software products are owned by Tektronix or its subsidiaries or suppliers, and are protected by national copyright laws and international treaty provisions.

Tektronix products are covered by U.S. and foreign patents, issued and pending. Information in this publication supercedes that in all previously published material. Specifications and price change privileges reserved.

TEKTRONIX and TEK are registered trademarks of Tektronix, Inc.

Velcro is a registered trademark of Velcro Industries B.V.

Tip-Clip is a trademark of Tektronix, Inc.

Contacting Tektronix

Tektronix, Inc.
14200 SW Karl Braun Drive
P.O. Box 500
Beaverton, OR 97077
USA

For product information, sales, service, and technical support:

- In North America, call 1-800-833-9200.
- Worldwide, visit www.tektronix.com to find contacts in your area.

Table of Contents

General Safety Summary	iii
Introduction	1
Theory of Operation	3
Input Voltage Limits	3
Maximum Input Voltage	3
Operating Voltage Window	4
Differential-Mode Signal Range	4
Common-Mode Rejection	4
Probing Techniques to Maximize Bandwidth	5
Input Impedance and Probe Loading	6
Electrical Effects of Accessories	7
Reference	9
Single-Ended Measurements	9
Differential Measurements	10
Common-Mode Rejection Ratio	10
Assessing CMRR Error	11
Input Impedance Effects on CMRR	11
Serial Bus Standards	12
Specifications	13
Warranted Characteristics	13
Typical Characteristics	14
Nominal Characteristics	17
Tip-Clip Assembly Specifications	18
Performance Verification	25
Equipment Required	25
Special Adapters Required	27
Equipment Setup	28
Output Offset Voltage	30
DC Gain Accuracy	31
Gain Check at 5X Attenuation	31
Gain Check at 25X Attenuation	32
Rise Time	33
Connecting to the Probe Calibration Fixture	33
Rise Time Check at 25X Attenuation	35
Test Record	39
User Service	41
Probe/Adapter/Oscilloscope Compatibility	41
Error Condition	41
Replacement Parts	41
Preparation for Shipment	42

List of Figures

Figure 1: Dynamic range	4
Figure 2: HBW Straight Flex, 8 mil Wire Tip-Clip Assembly	5
Figure 3: Typical probe input model	6
Figure 4: Simplified model of a differential amplifier	10
Figure 5: Typical Common-Mode Rejection Ratio (5X attenuation)	15
Figure 6: Probe and Tip-Clip dimensions	16
Figure 7: TekConnect-to-SMA Adapter	27
Figure 8: Probe Calibration Fixture	27
Figure 9: Preliminary test setup	28
Figure 10: Setup for the output offset zero test	30
Figure 11: DC Gain Accuracy setup	31
Figure 12: Reverse the power supply polarity on the probe inputs .	32
Figure 13: Tip-Clip Ejector	33
Figure 14: Probe calibration fixture and probe	34
Figure 15: Test system rise time setup	35
Figure 16: Setting the TDR parameters	36
Figure 17: Test probe rise time setup	37

List of Tables

Table 1: Offset ranges	9
Table 2: Serial bus standards	12
Table 3: Warranted electrical characteristics	13
Table 4: Typical electrical characteristics	14
Table 5: Typical mechanical characteristics	16
Table 6: Nominal electrical characteristics	17
Table 7: Test equipment	25
Table 8: Differential probe compatibility issues	41

General Safety Summary

Review the following safety precautions to avoid injury and prevent damage to this product or any products connected to it. To avoid potential hazards, use this product only as specified.

Only qualified personnel should perform service procedures.

While using this product, you may need to access other parts of the system. Read the *General Safety Summary* in other system manuals for warnings and cautions related to operating the system.

To Avoid Fire or Personal Injury

Connect and Disconnect Properly. Connect the probe output to the measurement instrument before connecting the probe to the circuit under test. Disconnect the probe input from the circuit under test before disconnecting the probe from the measurement instrument.

Observe All Terminal Ratings. To avoid fire or shock hazard, observe all ratings and markings on the product. Consult the product manual for further ratings information before making connections to the product.

Do not apply a potential to any terminal, including the common terminal, that exceeds the maximum rating of that terminal.

Do Not Operate Without Covers. Do not operate this product with covers or panels removed.

Avoid Exposed Circuitry. Do not touch exposed connections and components when power is present.

Do Not Operate With Suspected Failures. If you suspect there is damage to this product, have it inspected by qualified service personnel.

Do Not Operate in Wet/Damp Conditions.

Do Not Operate in an Explosive Atmosphere.

Keep Product Surfaces Clean and Dry.

Symbols and Terms

Terms in this Manual. These terms may appear in this manual:



WARNING. *Warning statements identify conditions or practices that could result in injury or loss of life.*



CAUTION. *Caution statements identify conditions or practices that could result in damage to this product or other property.*

Symbol on the Product. The following symbol may appear on the product:



Introduction

This manual discusses topics not covered or otherwise mentioned briefly in the *P7313 12.5 GHz and P7380 8 GHz 5X/25X Differential Probes User Manual*.

The following is a list of brief explanations:

- Theory of Operation — Contains probe details not mentioned in the user manual.
- Reference — Contains information about differential measurements and how to increase measurement accuracy.
- Specifications — Contains warranted, typical, and nominal characteristics for the probe and probe Tip-Clip Assemblies.
- Performance Verification — Describes the procedures for verifying the warranted specifications.
- User Service — Describes troubleshooting and probe maintenance.

Theory of Operation

This section discusses operating considerations and probing techniques. For more detailed information about differential measurements and common-mode rejection ratio (CMRR), see the *Reference* section on page 9.

The P7313 Probe is optimized for high bandwidth; it is not a general purpose probe. The probe head and tips are miniaturized for electrical characteristics and access to dense circuitry, and must be handled carefully.



CAUTION. To prevent damage to the probe, use care when handling the probe. Rough or careless use can damage the probe.

Input Voltage Limits

The P7313 Differential Probe is designed to probe low-voltage circuits. Before probing a voltage, take into account the limits for maximum input voltage, the common-mode signal range, and the differential-mode signal range. For specific limits, refer to page 14.

Maximum Input Voltage

The maximum input voltage is the maximum voltage to ground that the inputs can withstand without damaging the probe input circuitry.



CAUTION. To avoid damaging the inputs of the P7313 Differential Probe, do not apply more than ± 15 V (DC + peak AC) between each input or between either probe inputs and ground.

Operating Voltage Window

The operating voltage window defines the maximum voltage that you can apply to each input, with respect to earth ground, without saturating the probe input circuitry. See Figure 1. A common-mode voltage that exceeds the operating voltage window may produce an erroneous output waveform even when the differential-mode specification is met. For specifications, refer to page 14.

Differential-Mode Signal Range

The differential-mode signal range is the maximum voltage difference between the plus and minus inputs that the probe can accept without distorting the signal. The distortion from a voltage that is too large can result in a clipped or otherwise inaccurate measurement. The differential-mode signal range (the probe dynamic range) has a different value in the 5x and 25x attenuator settings, as shown in Figure 1. For specifications, refer to page 14.

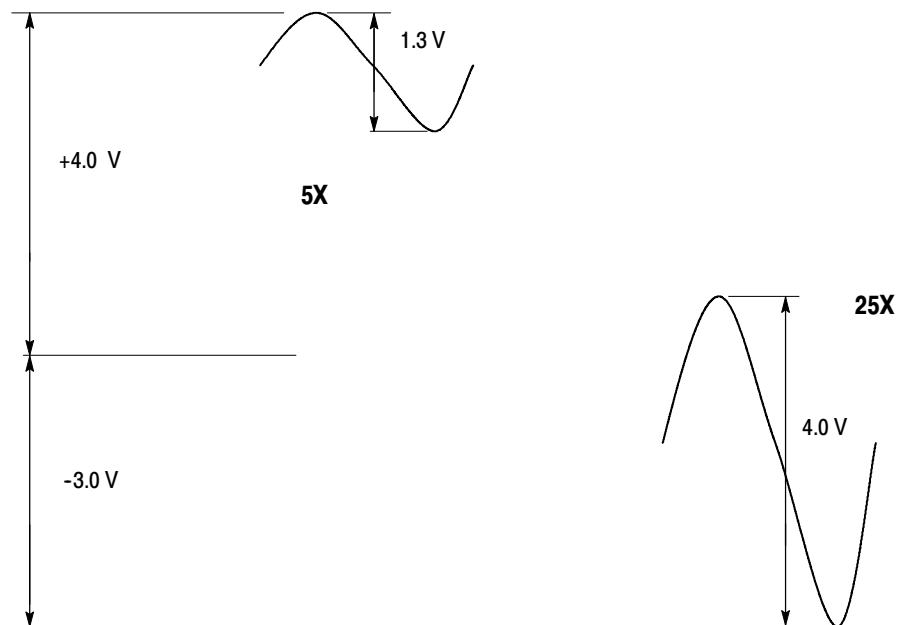

Figure 1: Dynamic range

Common-Mode Rejection

The common-mode rejection ratio (CMRR) is the ability of a probe to reject signals that are common to both inputs. More precisely, CMRR is the ratio of the differential gain to the common-mode gain. The higher the ratio, the greater the ability to reject common-mode signals. CMRR varies with frequency, usually decreasing at higher frequencies. For additional information about CMRR, see page 15.

Probing Techniques to Maximize Bandwidth

The bandwidth of the probe is highest when the probe is applied directly to the circuit with the HBW Straight Flex, 8 mil Wire, Tip-Clip Assembly shown in Figure 2. This Tip-Clip Assembly achieves the highest bandwidth when the Tip-Clip lead length is trimmed to about 50 to 75 mils. However, some probing tasks are made easier using other accessories included with the probe, particularly for probing applications when full bandwidth is not needed. See the Tip-Clip Assembly specifications starting on page 18 for the bandwidth performance of each Tip-Clip.

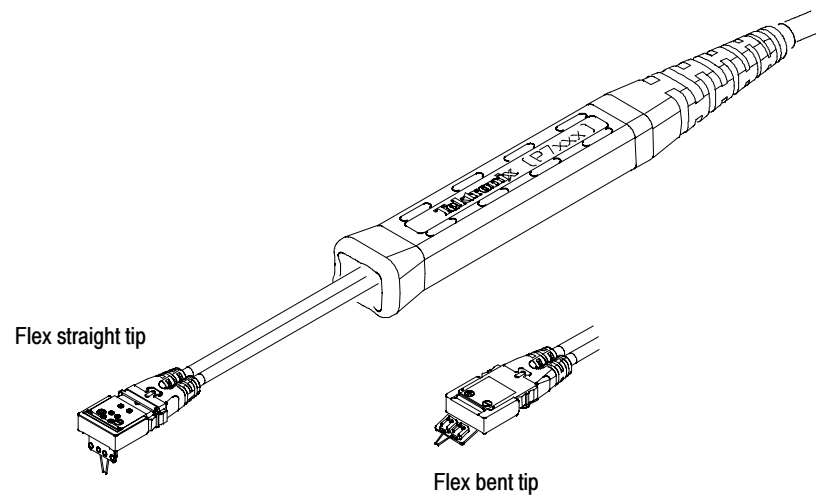

Figure 2: HBW Straight Flex, 8 mil Wire Tip-Clip Assembly

Input Impedance and Probe Loading

When you connect the probe inputs to a circuit, you are introducing a new resistance, capacitance, and inductance into the circuit. Each input of the differential probe has a characteristic input impedance of 50 k Ω to ground.

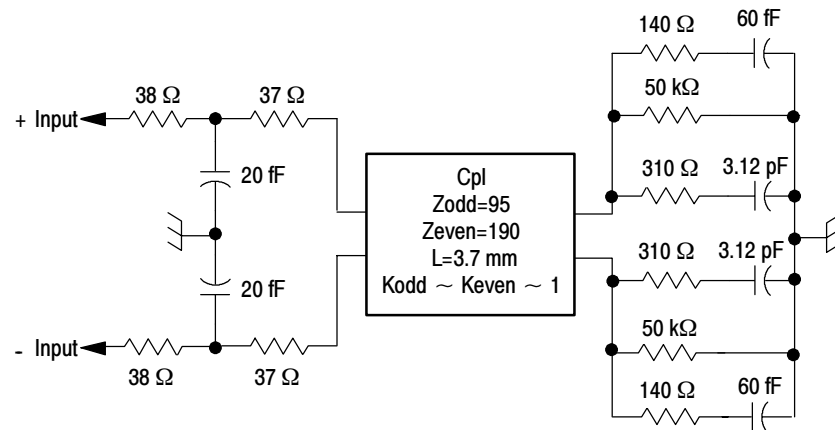

Figure 3: Typical probe input model

For signals with low source impedance and frequency, the 50 k Ω input impedance on each input is large enough to prevent the inputs from loading the signal sources. As the signal source impedance on an input increases, the more the probe loads the source and reduces the signal amplitude. The greater the source impedances and the higher the signal frequencies, the more you must take these factors into account. See Figure 3.

The frequency of the signal also affects signal measurement. As the frequency of the signal increases, the input impedance of the probe decreases. The lower the impedance of the probe relative to that of the source, the more the probe loads the circuit under test and reduces the signal amplitude. For graphs of input impedance versus frequency, refer to the Tip-Clip Assembly specifications starting on page 18.

Electrical Effects of Accessories

The Tip-Clip accessories included with your probe help connect to different types of components. The Tip-Clip accessories are designed to provide optimum performance as a system. Each Tip-Clip accessory has distinct characteristics. While these accessories make connections easier, be aware that the Tip-Clip accessory you choose affects the signal you are measuring, depending on a variety of factors, including signal frequency, source impedance, and lead length. Refer to *Specifications* on page 13 for more Tip-Clip information.

Reference

This section contains important reference information about differential measurements and how to increase measurement accuracy.

Single-Ended Measurements

A differential probe, for example the P7313 Differential Probe, can be used for single-ended measurements within the limits of its dynamic and offset voltage ranges. Single-ended probes such as the P7260 typically have a wider offset range than corresponding differential probes (see Table 1).

Table 1: Offset ranges

Probe	DC Offset, 5X	Dynamic Range, 5X	DC Offset, 25X	Dynamic Range, 25X
P7260	$\pm 5\text{ V}$	1.5 V _{PP}	$\pm 5\text{ V}$	5 V _{PP}
P7313 Differential Probe	+4 V, -3 V	1.25 V _{PP}	+4 V, -3 V	4 V _{PP}

Differential probes are ideal for a class of single-ended measurements where the reference voltage is not ground:

- SSTL_1,2: $V_{TT}, V_{REF} = V_{DD}/2$
- PECL: $V_{REF} = V_{CC}-1.3$

To measure single-ended signals in this class, connect the negative input of the P7313 Differential Probe to V_{REF} .

A differential probe in these applications displays the true signal despite any AC or DC variation in V_{REF} from its nominal value. While a single-ended probe, which is ground referenced, displays the signal plus the variation in V_{REF} .

Differential probes can also be used to make ground referenced single-ended measurements on either single-ended signals or differential signals like PCI Express or Serial ATA. To measure ground referenced single-ended signals, connect the negative input of the P7313 Probe to ground.

Single-ended measurements on differential signals are used to measure common mode voltage and check for differential signal symmetry.

Differential Measurements

A differential probe does not need to be referenced to ground. The balanced inputs of a differential probe provide greater flexibility and performance in most measurement applications.

Devices designed for differential measurements avoid common-mode noise problems presented by single-ended systems. These devices include a variety of differential probes, differential amplifiers, and isolators.

The differential amplifier (Figure 4), is used to make differential measurements that reject any voltage that is common to the inputs and amplifies any difference between the inputs. Voltage that is common to both inputs is often referred to as the Common-Mode Voltage (V_{CM}) and voltage that is different as the Differential-Mode Voltage (V_{DM}).

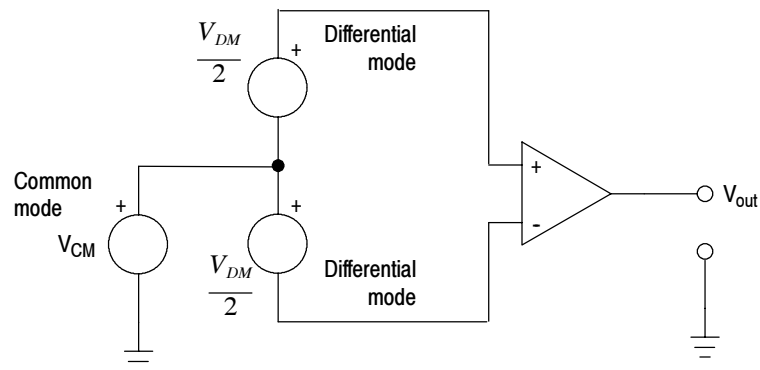

Figure 4: Simplified model of a differential amplifier

Common-Mode Rejection Ratio

Differential amplifiers cannot reject all of the common-mode signal. The ability of a differential amplifier to reject the common-mode signal is expressed as the Common-Mode Rejection Ratio (CMRR). The CMRR is the differential-mode gain (A_{DM}) divided by the common-mode gain (A_{CM}). It is expressed either as a ratio or in dB.

$$CMRR = \frac{A_{DM}}{A_{CM}} \quad dB = 20 \log \frac{A_{DM}}{A_{CM}}$$

CMRR generally is highest (best) at DC and degrades with increasing frequency.

Assessing CMRR Error

Figure 5 on page 15 shows the CMRR of the P7313 Differential Probe. This derating graph assumes a sinusoidal common-mode signal.

A quick way to assess the magnitude of CMRR error when the common-mode signal is not sinusoidal is to connect both leads to the same point in the circuit. The oscilloscope displays only the common-mode component that is not fully rejected by the probe. While this technique may not give you accurate measurements, it does allow you to determine if the magnitude of the common-mode error signal is significant. Make the probe Tip-Clip wires the same length to maximize the probe CMRR.

**Input Impedance Effects
on CMRR**

The lower the input impedance of the probe relative to the source impedance, the lower the CMRR for a given source impedance imbalance. Differences in the source impedance driving the two inputs lowers the CMRR. Note that single-ended measurements generally result in asymmetric source impedances which tend to reduce the differential mode CMRR.

Serial Bus Standards

Table 2 lists some popular high-speed data communication standards that are measured with the P7313 Differential Probe.

Table 2: Serial bus standards

Serial bus data rate	Clock frequency	3 rd harmonic	5 th harmonic
InfiniBand 2.5 Gb/s	1.25 G3.75	3.75 GHz	6.25 GHz
PCI Express 2.5 Gb/s	1.25 GHz	3.75 GHz	6.25 GHz
SATA II 3.0 Gb/s	1.50 GHz	4.50 GHz	7.50 GHz
XAUI 3.125 Gb/s	1.56 GHz	4.69 GHz	7.81 GHz
Fibre Channel 4.25 Gb/s	2.125 GHz	6.375 GHz	10.625 GHz
FB-DIMM 4.8 Gb/s	2.4 GHz	7.2 GHz	12.0 GHz
PCI-express II 5.0 Gb/s	2.5 GHz	7.50 GHz	12.5 GHz
SATA III 6.0 Gb/s	3.0 GHz	9.0 GHz	15.0 GHz
2x XAUI 6.25 Gb/s	3.125 GHz	9.375 GHz	15.625 GHz
Fibre Channel 8.5 Gb/s	4.25 GHz	12.75 GHz	21.25 GHz
XFI 10.0 Gb/s	5.0 GHz	15.0 GHz	25.0 GHz

Specifications

The specifications in Tables 3 through 6 apply to the P7313 Differential Probe installed on any TekConnect instrument or Tektronix 80A03 TekConnect adapter. When the probe is used with another oscilloscope, the oscilloscope must have an input impedance of 50 Ω . The probe must have a warm-up period of at least 20 minutes and be in an environment that does not exceed the limits described in Table 3. Specifications for the P7313 Differential Probe fall into three categories: warranted, typical, and nominal characteristics.

Warranted Characteristics

Warranted characteristics (Table 3) describe guaranteed performance within tolerance limits or certain type-tested requirements. Warranted characteristics that have checks in Table 3 are marked with the ✓ symbol.

Table 3: Warranted electrical characteristics

Characteristic	Description
✓ DC attenuation accuracy	$\pm 2\%$
✓ Output Zero	± 3 mV (+20 to +30 °C, +68 to +86 °F) (5X) ± 15 mV on oscilloscope ± 3 mV (+20 to +30 °C, +68 to +86 °F) (25X) ± 75 mV on oscilloscope
✓ Rise time	<40 ps (probe only, HBW Straight Flex, 8 mil Wire, Tip-Clip Assembly), all other Tip-Clip assemblies are typical
Temperature	Operating: 0 to +40 °C (+32 to +104 °F), Nonoperating: -55 to +75 °C (-131 to +167 °F) ¹
Humidity	Operating: 0-90% RH, tested at +0 to +40 °C (+32 to +104 °F) Nonoperating: 0-90% RH, tested at -55 to +75 °C (+67 to +167 °F)

¹ See warning that follows.



WARNING. To avoid a burn hazard at high ambient temperatures, do not touch the probe with bare hands at nonoperating temperatures above +75 °C (+167 °F). Allow sufficient time for the probe to cool before handling.

Typical Characteristics

Typical characteristics (Tables 4 and 5) describe typical but not guaranteed performance.

Table 4: Typical electrical characteristics

Characteristic	Description
Differential input resistance, DC coupled	104 k Ω \pm 2%
Common-mode input resistance, DC coupled	52 k Ω \pm 1 k Ω
Differential offset range	-3.0 V to +4 V
Noise	< 31 nV/ $\sqrt{\text{Hz}}$ (5X)
	< 75 nV/ $\sqrt{\text{Hz}}$ (25X)
Input impedance	See <i>Tip-Clip assemblies</i> starting on page 18 for more detailed information.
Bandwidth	See <i>Tip-Clip assemblies</i> starting on page 18 for more detailed information. (+ 2.0dB, -3 dB) for an ambient temperature range of 20 °C to 30 °C
Small signal rise time	See <i>Tip-Clip assemblies</i> starting on page 18 for more detailed information. Ambient temperature range of 20 °C to 30 °C
Common-mode rejection ratio	See Figure 5 >50 dB at DC — 1 MHz (tested at DC) >35 dB at 1 GHz >20 dB at 6 GHz >15 dB at 12.5 GHz
Maximum non destructive input voltage	\pm 15 V _(DC + peak AC) between each input or between either probe inputs and ground.
Differential signal range (DC coupled)	\pm 0.625 V at attenuation setting of 5X \pm 2.0 V at attenuation setting of 25X
Operating Voltage Window	-3.0 V to +4.0 V at (5X or 25X)
Linearity	\pm 0.75% over a dynamic range of -0.625 V to +0.625 V for 5X \pm 1.0% over a dynamic range of -2.0 V to +2.0 V for 25X
DC offset drift	50 $\mu\text{V}/^\circ\text{C}$ (at the output of the probe) 0.25 mV/ $^\circ\text{C}$ (displayed on screen with the TekConnect interface)
DC voltage measurement accuracy	\pm (2% of input + (2% of offset) + 50 mV + 7.5 mV) 5X \pm (2% of input + (2% of offset) + 50 mV + 40 mV) 25X

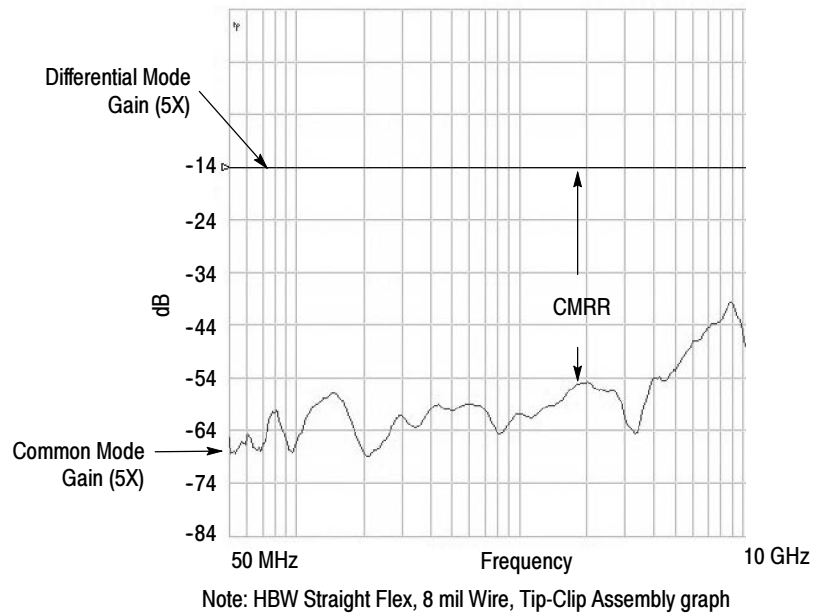

Figure 5: Typical Common-Mode Rejection Ratio (5X attenuation)

Table 5: Typical mechanical characteristics

Characteristic	Description
Dimensions, compensation box	107 mm × 41 mm × 26 mm (4.2 in × 1.6 in × 1.0 in)
Dimensions, probe head	19.43 mm × 3.30 mm × 7.6 mm (0.765 in × 0.130 in × 0.300 in)
Dimensions, cable length	1.2 m (47 in) (from the probe head to the compensation box)
Unit weight	1.550 g (3.1 lbs) (probe, accessories and packaging)

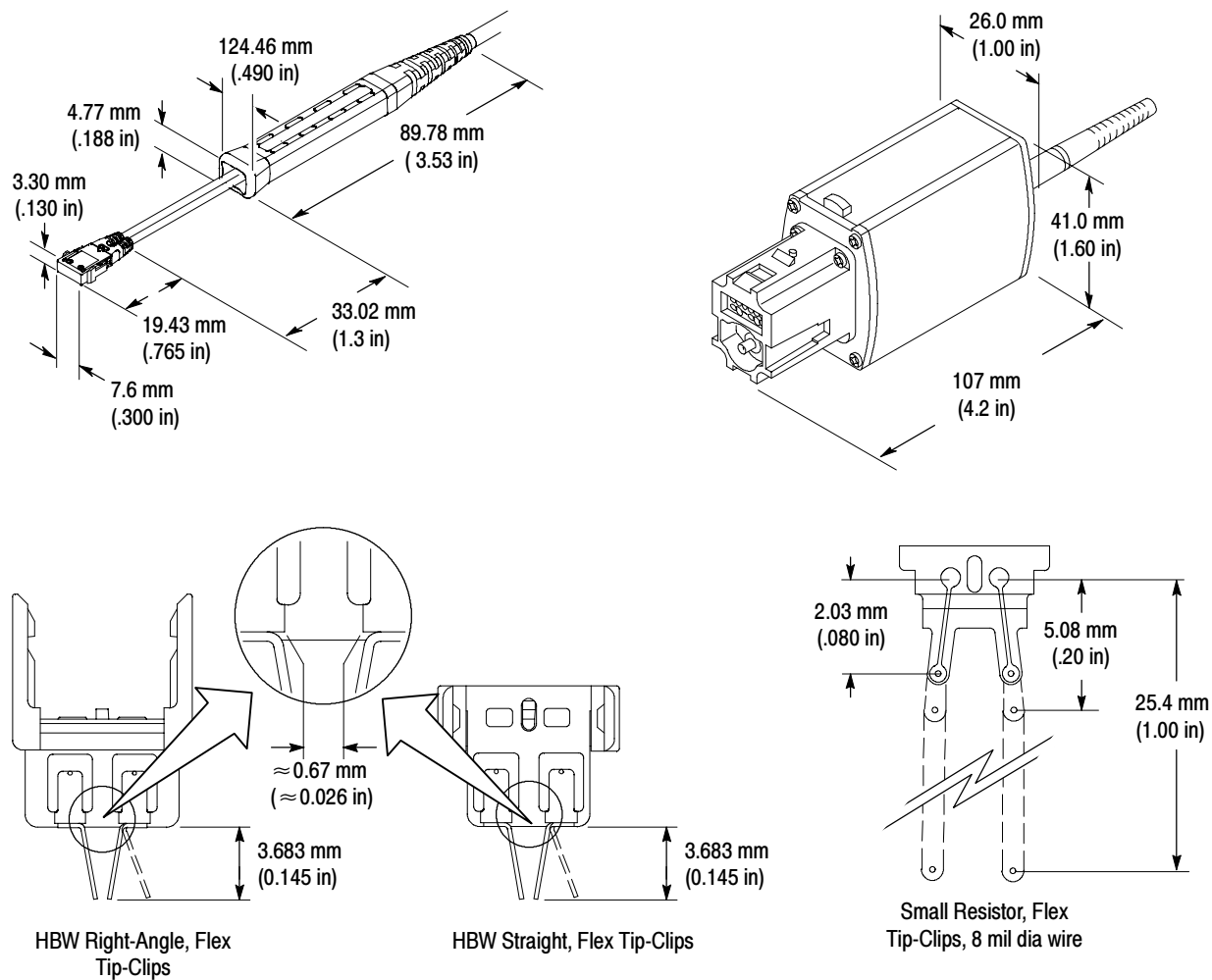

Figure 6: Probe and Tip-Clip dimensions

Nominal Characteristics

Nominal characteristics (Table 6) describe guaranteed traits, but the traits do not have tolerance limits.

Table 6: Nominal electrical characteristics

Characteristic	Description
Input configuration	Differential (two inputs, + and -)
Output coupling	DC
Attenuation settings	5X and 25X
Termination	Terminate output into 50 Ω

Tip-Clip Assembly Specifications

Note. All specifications are typical in the following Tip-Clip assemblies, unless otherwise indicated.

HBW Straight Flex, 8 mil wire, Tip-Clip Assembly

Tektronix part number:
020-2639-XX (Qty 10)
020-2657-XX (Qty 5)

Bandwidth: >12.5 GHz
10/90 Rise time: <40 ps*
20/80 Rise time: <25 ps
*Guaranteed

Loading: Differential $Z_{MIN} > 200 \Omega$ to 10 GHz

High bandwidth and good signal fidelity, ideal for connecting to large components.

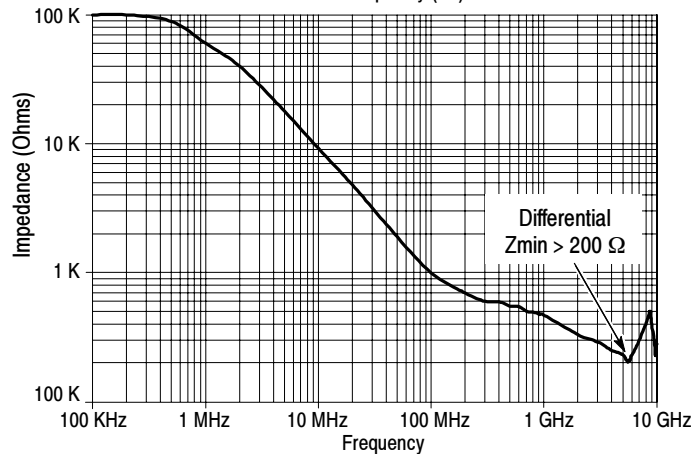
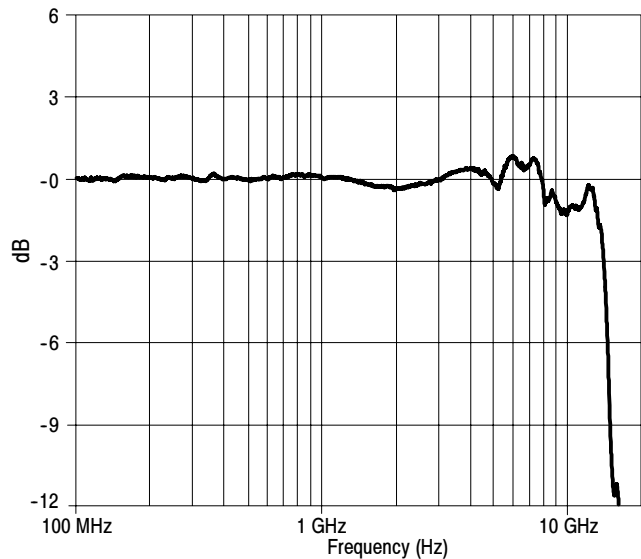
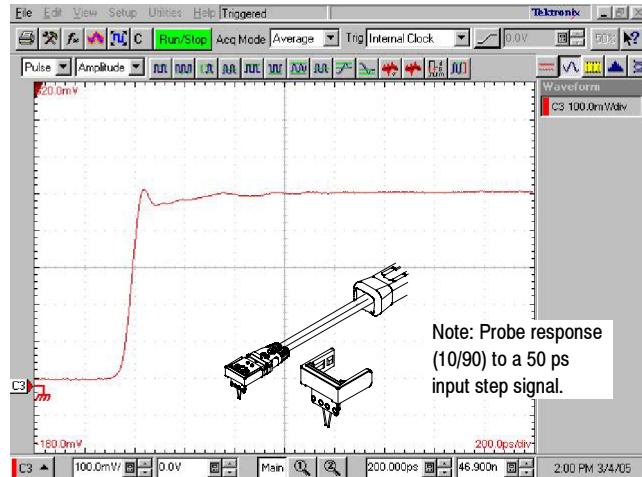

**HBW Right-Angle Flex, 8 mil Wire,
Tip-Clip Assembly**

Tektronix part number: 020-2638-XX (Qty 10)
020-2656-XX (Qty 5)

Bandwidth: >12 GHz
10/90 Rise time: <42 ps
20/80 Rise time: <27 ps

Loading: To be announced

Best probe loading for HBW Tip-Clip Assemblies. Using the Wire Replacement Kit allows you the flexibility to solder 8 mil or 4 mil wires to small circuit board vias.

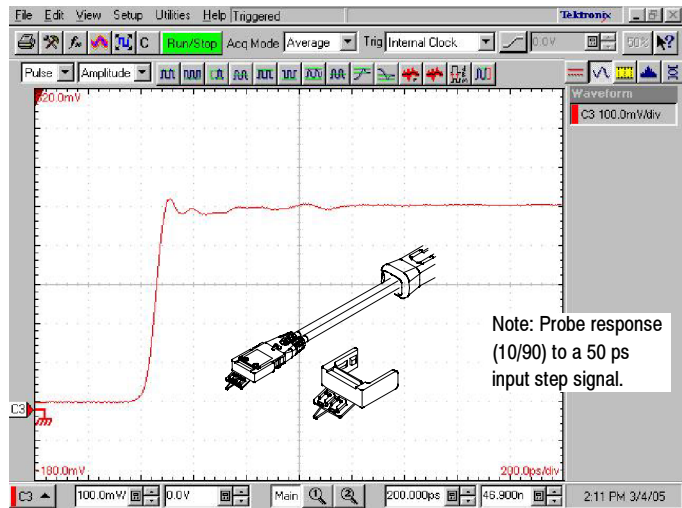

CAUTION. Avoid overstressing the flex by not pushing the flex past 90°. May cause the flex to become intermittent.

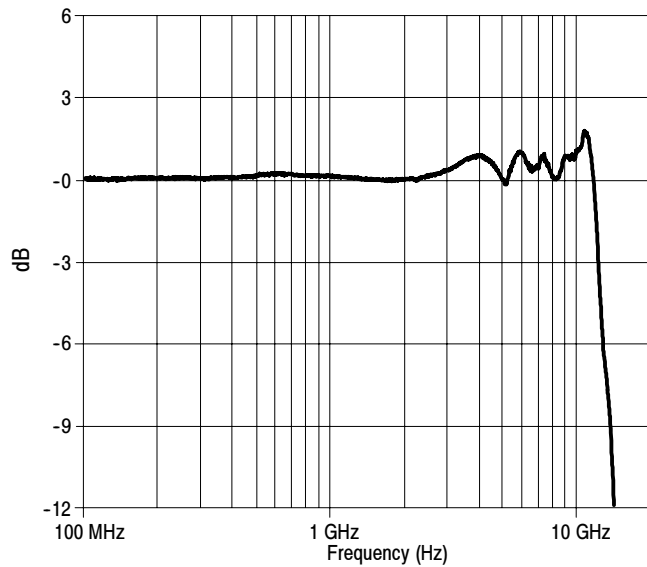
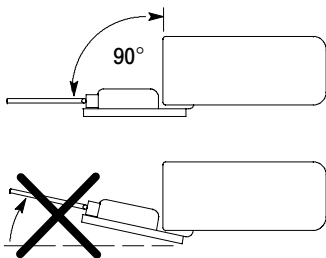

**Short Flex, Small Resistor,
Tip-Clip Assembly**

Tektronix part number: 020-2600-XX

Bandwidth: >8.0 GHz
 10/90 Rise time: <55 ps*
 20/80 Rise time: <35 ps
 *Guaranteed

Loading: Differential Z_{MIN} 290 Ω to 8 GHz

Best overall signal fidelity. The small resistors are ideal for connecting to small circuit board vias and fine pitch circuitry.

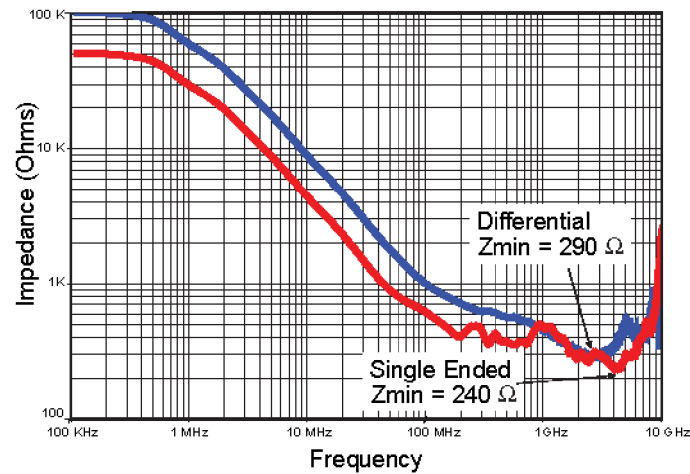
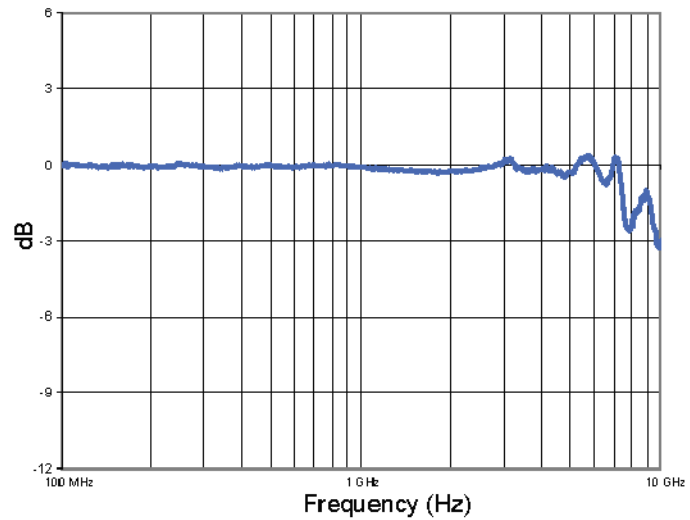
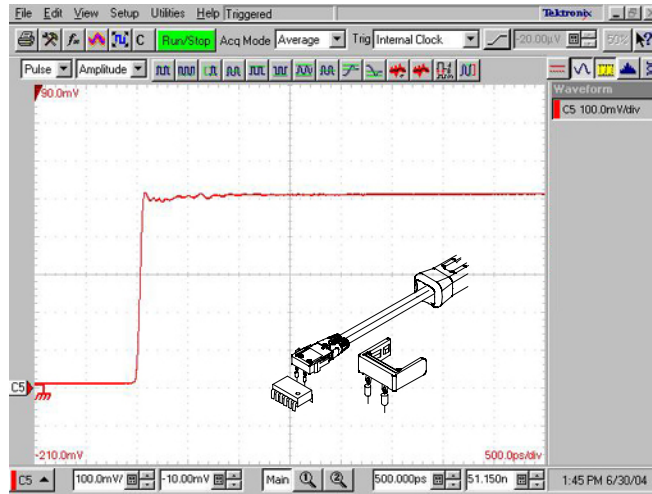

Medium Flex, Small Resistor, Tip-Clip Assembly

Tektronix part number: 020-2602-XX

Bandwidth: >7.0 GHz
 10/90 Rise time: <55 ps
 20/80 Rise time: <35ps

Loading: Differential Z_{MIN} 290 Ω to 8 GHz

Good compromise between ease-of-use and maximum performance when attaching to smaller devices or circuit board vias.

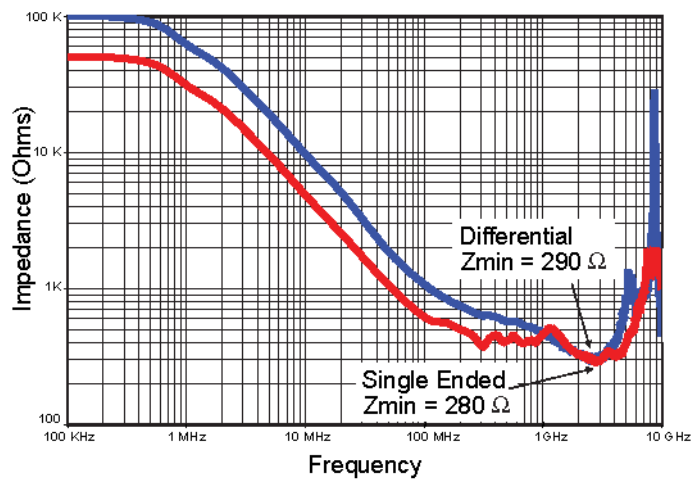
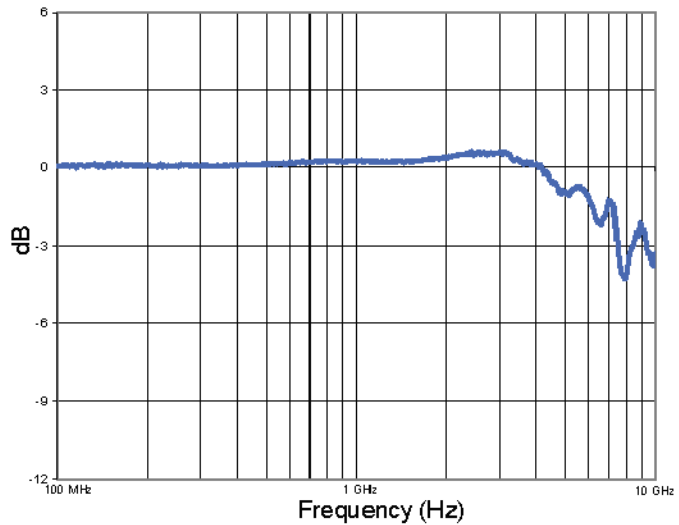
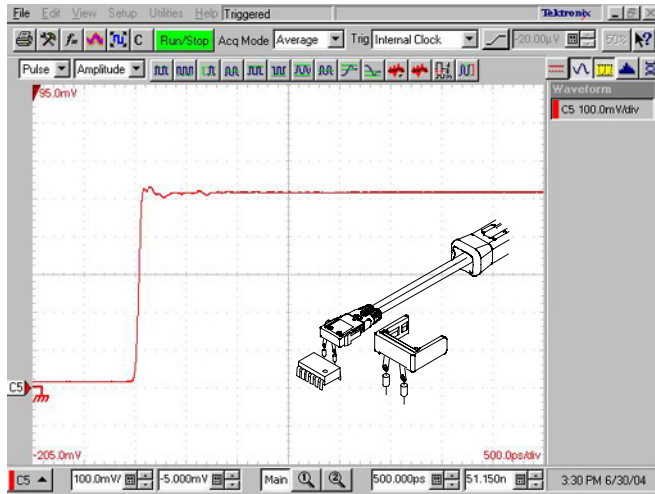

**Long Flex, Small Resistor,
Tip-Clip Assembly**

Tektronix part number: 020-2604-XX

Bandwidth: >6.0 GHz
 10/90 Rise time: <130 ps
 20/80 Rise time: <40 ps

Loading: Differential Z_{MIN} 360 Ω to
 8 GHz

Extended reach with good step response.
 Useful for connecting to hard to reach
 small circuit board vias and fine-pitch
 circuitry. Conveniently sized to fit between
 DIMM modules. Not recommended for
 signals faster than 4 GHz.

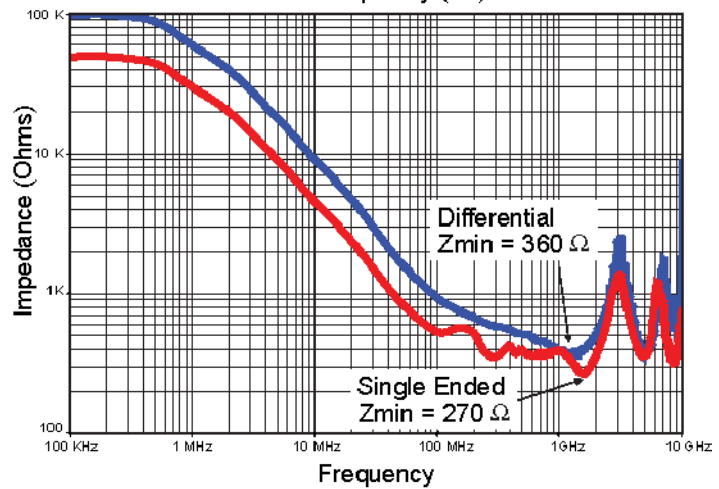
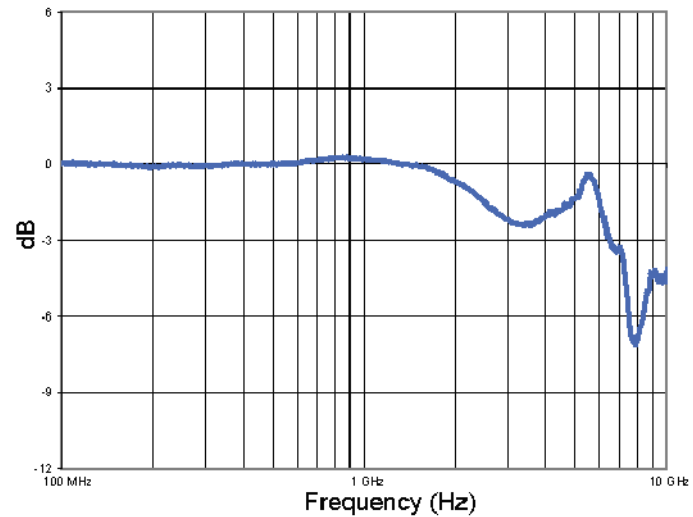
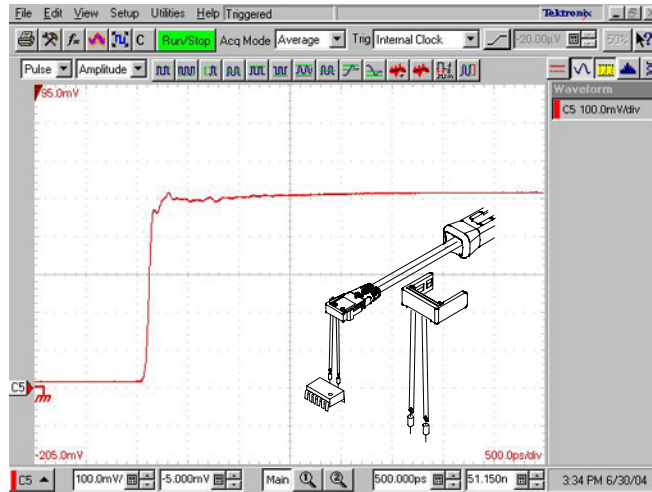

Variable Spacing Tip-Clip Assembly

Tektronix part number: 020-2596-XX

Optional accessory, not included with the probe.

Bandwidth: >8 GHz
 T_R : 10/90 <55 ps, 20/80 <35 ps
 Loading: Differential Z_{MIN} 220 Ω to 8 GHz

Use the Variable Spacing Tip-Clip Assembly for probing test points spaced from 0.020-in to 0.180-in apart.

Exercise care when handling the articulated pins.

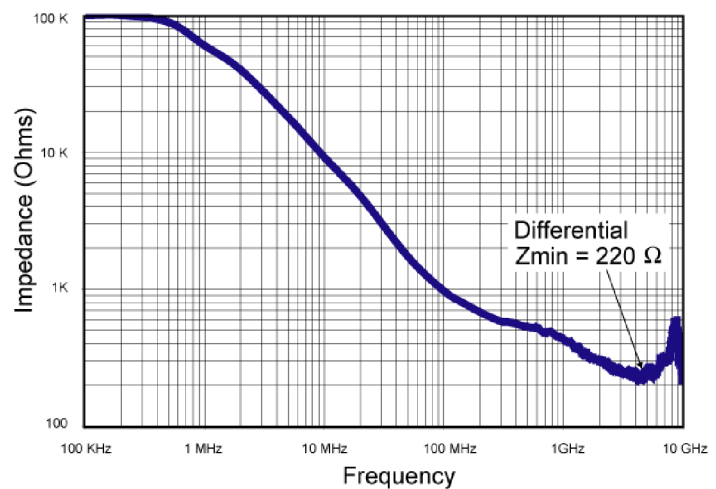
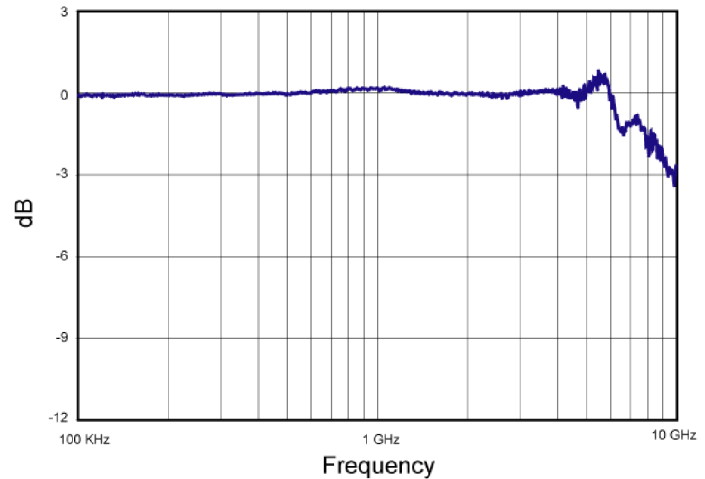
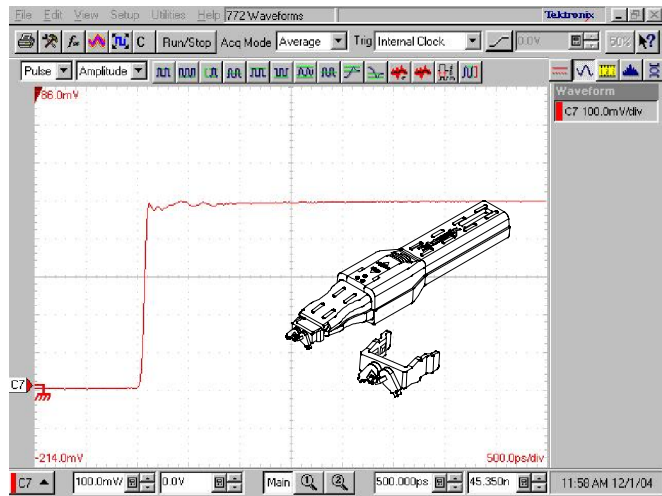

Performance Verification

The following procedures verify the warranted output offset voltage, DC attenuation accuracy, and rise time specifications of the P7313 Differential Probe. The recommended calibration interval is one year.



CAUTION. To avoid ESD damage to the probe, always use an antistatic wrist strap (provided with your probe), and work at a static-approved workstation when handling the probe.



Equipment Required

Table 7 lists the equipment required for the performance verification procedure. The types and quantities of connectors depends on the specific equipment you use.

Table 7: Test equipment

Description and quantity	Performance requirement	Recommended example ¹
Sampling Oscilloscope		Tektronix TDS8200 Series
Sampling Module	20 GHz bandwidth	Tektronix 80E03 or 80E04
Pulse Generator	<25 ps rise time	Tektronix 80E04 TDR
Sampling Head Extender Cable	1 m	012-1568-00
TekConnect Probe Interface Module with semi-rigid cable	Firmware version V2.0 and above	Tektronix 80A03, with 174-4857-XX cable
TekConnect-to-SMA adapter	See page 27	Tektronix TCA-SMA
DMM (2), with leads	0.1 mV	Fluke 187 or equivalent
Dual Power Supply	5.0 VDC at 200 mA	B+K Precision 1760A or equivalent
Coaxial cable	Male-to-Male BNC, 50 Ω	012-0057-XX
Test leads	Banana plug ends, red	012-0031-XX
Test leads	Banana plug ends, black	012-0039-XX
Test leads (2)	Mini plunger with test clip	Mueller BU-1120

Table 7: Test equipment (cont.)

Description and quantity	Performance requirement	Recommended example ¹
Adapter	BNC(M)-to-Minigrabbers	013-0342-XX
Adapter	SMA Male-to-BNC female	015-1018-XX
Adapter	SMA Male-to-Male	015-1011-XX
Feed through termination	BNC, 50 Ω \pm 0.05 Ω	011-0129-XX
Probe calibration fixture	See page 27	067-1616-XX
Long Flex, Small Resistor, Tip-Clip Assembly	See page 22	020-2604-XX ²
HBW Straight Flex, 8 mil wire, Tip-Clip Assembly	See page 18	020-2639-XX ²
SMA torque wrench	5/16-in, 7 in-lb.	
Tweezers	For removing probe tips (see page 34).	

¹ **Nine-digit part numbers (xxx-xxxx-xx) are Tektronix part numbers.**

² **Standard accessories included with the probe.**

- **Optional Tool.** A torque wrench helps to ensure reliable connections by meeting the nominal torque values listed in these instructions.

Special Adapters Required

Some of the adapters listed in Table 7 are available only from Tektronix. These adapters are described on the following pages.

TekConnect-to-SMA Adapter

The TekConnect-to-SMA Adapter, Tektronix part number TCA-SMA, lets you connect an SMA cable to a TekConnect input. See Figure 7. Connect and disconnect the adapter the same way as you do the probe.

This adapter is an oscilloscope accessory that can be used for measurement applications, as well as these performance verification procedures.

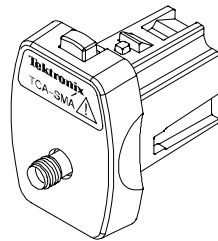

Figure 7: TekConnect-to-SMA Adapter

Probe Calibration Fixture

Some of the procedures in this manual use a probe calibration fixture, Tektronix part number 067-1616-XX.

The calibration fixture provides a means to test the probe for the single-ended rise time measurement. SMA connectors on the front and back of the fixture allow you to apply stimulus signals to pass through the fixture for access by the probe.

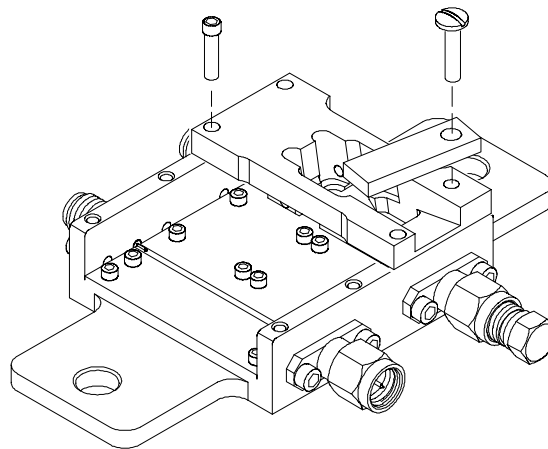
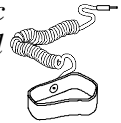

Figure 8: Probe Calibration Fixture

Equipment Setup



CAUTION. To avoid ESD damage to the probe, always use an antistatic wrist strap (provided with your probe), and work at a static-approved workstation when handling the probe.



Before performing the following verification procedures in order, power off the TDS 8200 oscilloscope.

Use the following procedure to set up and warm the equipment to test the probe.

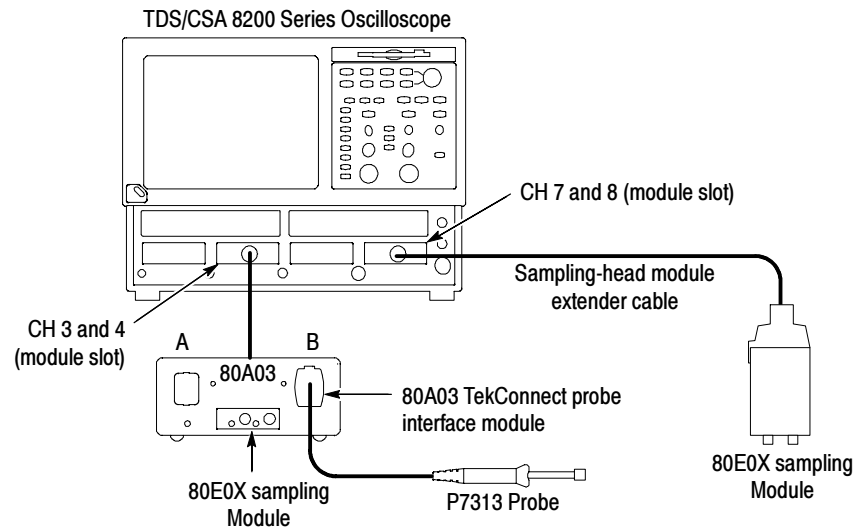

Figure 9: Preliminary test setup

1. Connect the 80A03 TekConnect probe interface to the channel 3 and 4 slot of the TDS 8200 oscilloscope. See Figure 9.
2. Connect the 80E0X sampling module to the 80A03 TekConnect probe interface. Do not attach the semi-rigid SMA cable at this time.
3. Connect the probe to one of the 80A03 TekConnect probe interface channels.
4. Connect the sampling-head module extender cable to the channel 7 and 8 slot of the TDS 8200 oscilloscope.
5. Connect the 80E0X sampling module to the end of the sampling module extender cable. You may leave the sampling-head module extender cable and module connected for the rest of the performance verification procedures.

6. Turn on the oscilloscope and allow 20 minutes for the equipment to warm up. The TekConnect Interface status LED lights green when the probe is recognized and powered on.
7. From the Utilities menu, select Compensation, then follow the directions in the oscilloscope display to compensate and save the compensation for module channels 3 and 4. Complete the compensation procedure on both Sampling modules.
8. Photocopy the test record on page 39 to record the performance test results.

Output Offset Voltage

NOTE. Before beginning these procedures, refer to page 39 and photocopy the test record (if you have not already done so) and use it to record the performance test results.

Use the following procedure to test the Output Offset voltage.

1. After the probe is connected to the 80A03 module and warmed up, connect the equipment as shown in Figure 10.
2. Use the BNC(m)-to-Minigrabber (black) Minigrabber clips to short the two Tip-Clip leads together (see Figure 10).

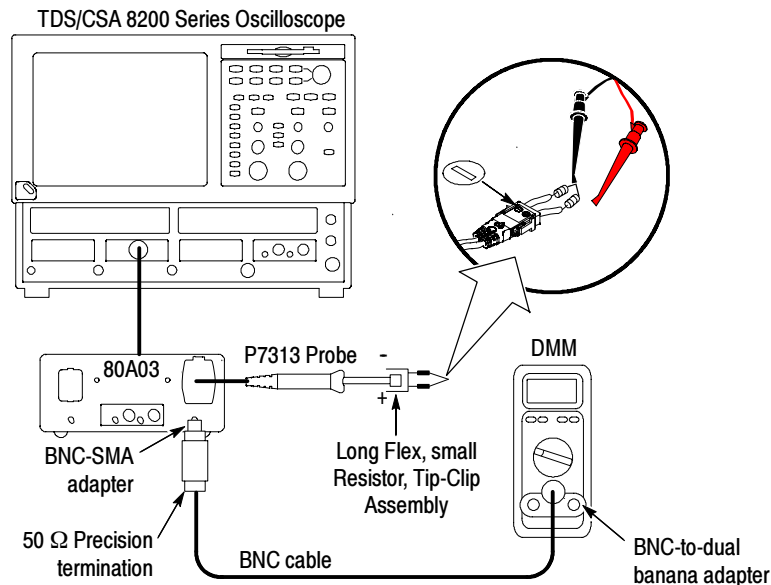

Figure 10: Setup for the output offset zero test

3. Set the multimeter to read DC volts.
4. Verify that the output voltage is $0\text{ V} \pm 3.0\text{ mV}$ for both the 5X and 25X attenuation settings.
5. Record the results on the test record.

DC Gain Accuracy

This test checks the DC gain accuracy of the probe at the 5X and 25X attenuation settings.

Gain Check at 5X Attenuation

1. Set the probe attenuation to 5X.
2. Connect the probe with a Tip-Clip Assembly to the power supply as shown in Figure 11. Monitor the source voltage with one of the DMMs.

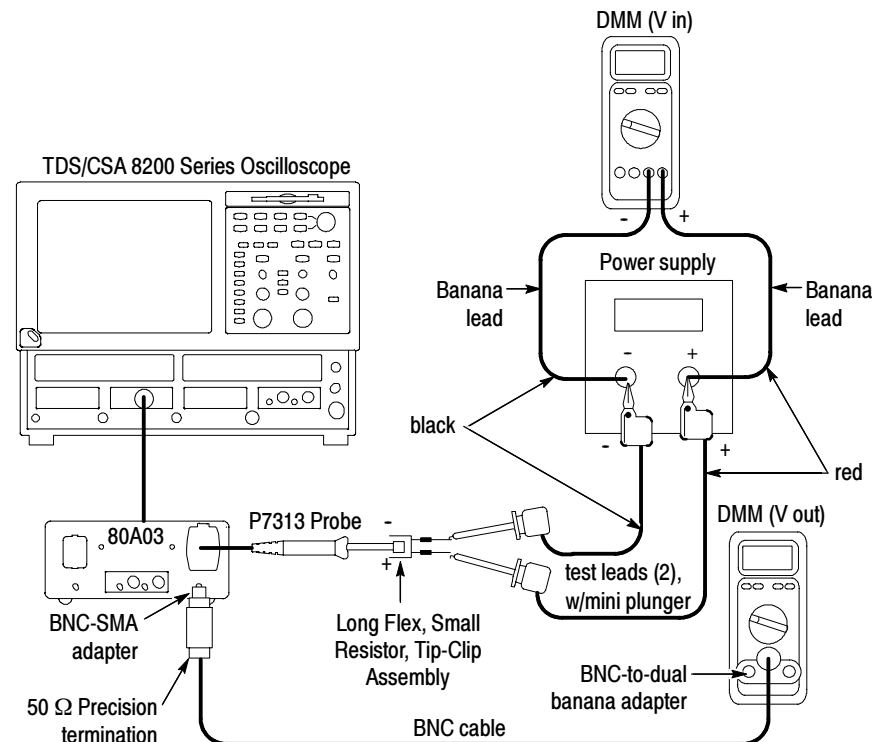

Figure 11: DC Gain Accuracy setup

3. Set the power supply to approximately +0.5 V. This represents 80% of the probe dynamic range in this attenuation setting. Record this source voltage as V_{in1} .
4. Record the output voltage (on the second DMM) as V_{out1} .
5. Disconnect the test leads from the power supplies. Leave the DMM leads connected to the adapters.
6. Reverse the polarity of the voltage applied to the probe inputs by swapping both sets of banana leads at the power supplies, as shown in Figure 12.
7. Record the actual source voltage (now a negative value), as V_{in2} .

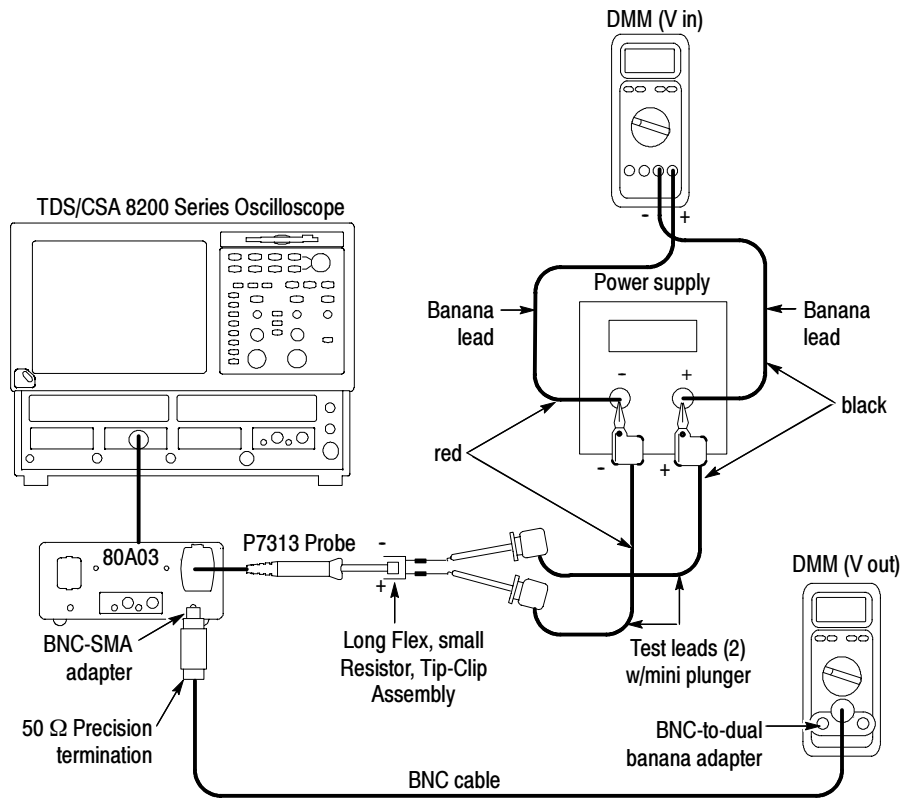

Figure 12: Reverse the power supply polarity on the probe inputs

8. Record the output voltage on the second DMM (now a negative value) as V_{out2} .
9. Calculate the gain as follows: $(V_{out1} - V_{out2}) \div (V_{in1} - V_{in2})$.
10. Verify that the gain is 0.2, $\pm 2.0\%$.
11. Record the calculated gain for the 5X setting on the test record.

Gain Check at 25X Attenuation

1. Set the attenuation on the probe to 25X.
2. Repeat steps 2 through 9, but in step 3, set the power supply to 1.6 V.
3. Verify that the gain is 0.04, $\pm 2.0\%$.
4. Record the calculated gain on the test record.

Rise Time

This procedure verifies that the probe meets the rise time specification. Two rise times are measured; the test system alone, and the test system with the probe included. The probe rise time is calculated using the two measurements.

This test uses the TDR function of the 80E0X sampling module as a fast rise time signal source. The rise time measurements are made using an 80A03 TekConnect probe interface with an 80E03 or 80E04 Sampling Head Module. Although the following procedure assigns measurement functions to specific oscilloscope channels, any valid channel combination can be used.

This test checks both of the probe attenuation settings.

Review *Connecting to the Probe Calibration Fixture* on page 33 if you have not used the calibration fixture before.

Connecting to the Probe Calibration Fixture



Follow these instructions to connect or disconnect the Probe Calibration Fixture.

CAUTION. To prevent damage to the probe tip when removing it from the fixture, a Tip-Clip Ejector must be attached to the probe tip before connecting to the calibration fixture. Removal is difficult without a Tip-Clip Ejector in place on the probe tip. See Figure 13.

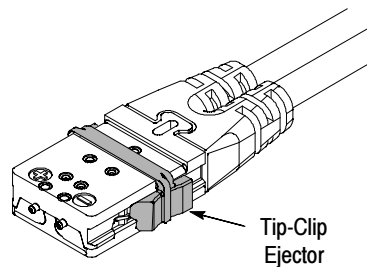

Figure 13: Tip-Clip Ejector

1. Loosen the plastic screw and swing the retainer bar out of the way. See Figure 14 on page 34.
2. Position the probe tip so that the Tip-Clip Ejector is visible. Note that the + polarity marking goes to the signal trace on the calibration fixture.
3. Slide the probe tip in to the probe Tip-Clip Assembly embedded in the probe calibration fixture. You will feel the probe tip click into place.

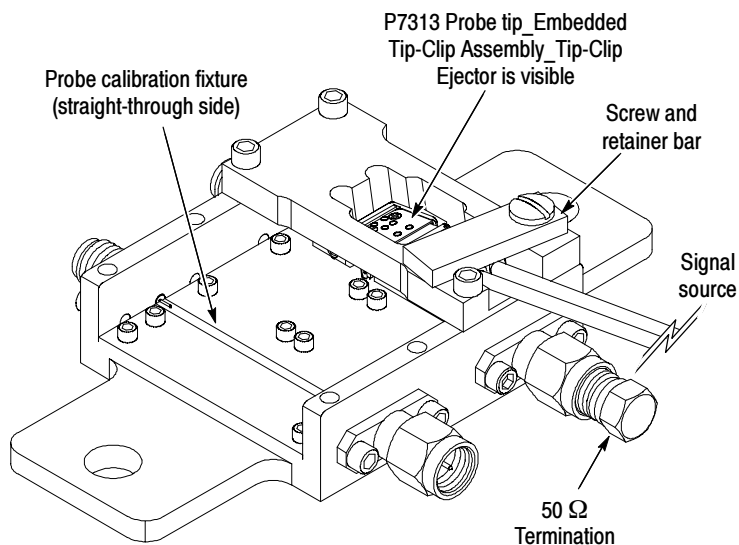

Figure 14: Probe calibration fixture and probe

4. Swing the retainer bar back over the probe and gently tighten the plastic screw.

Removing the Probe Tip.

1. Loosen the plastic screw and swing the retainer bar out of the way. See Figure 14.
2. Using tweezers, push the Tip-Clip Ejector towards the probe and away from the embedded Tip-Clip Assembly. You will feel the Tip-Clip Ejector click past a ridge on the probe tip and the probe tip will loosen.
3. Remove the loosened probe tip from the calibration fixture.

Rise Time Check at 25X Attenuation

1. Connect the test equipment as shown in Figure 15. Provide support under the 80E04 Pulser to avoid stressing the connectors.
2. Connect the semi-rigid SMA connector between the 80A03 probe output and the 80E0X module input. Provide support under the 80E04 Pulser to avoid stressing the connectors.

NOTE. To prevent mechanical strain on the connectors, use care when working with SMA connectors: Support equipment and use a torque wrench to tighten connections to 7 in-lbs.

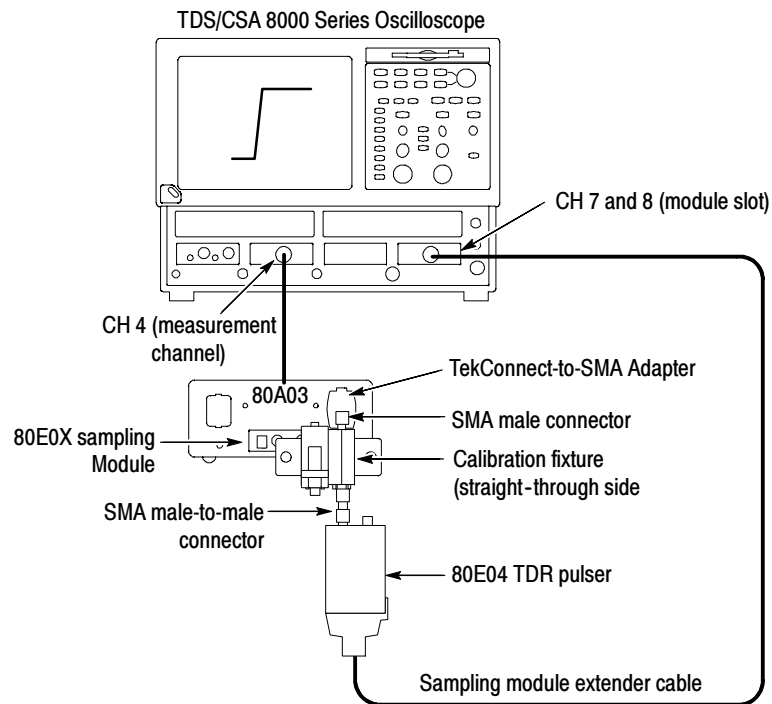

Figure 15: Test system rise time setup

NOTE. The 80A03 firmware version must be version V 2.0 or above. The firmware version label is on the rear panel of the instrument.

3. Turn on Channel 4, and set the vertical scale to 50 mV/div.

- Set the Channel 8 sampling head to TDR mode:
Press the **SETUP DIALOGS** button and select the **TDR** tab. See Figure 16.

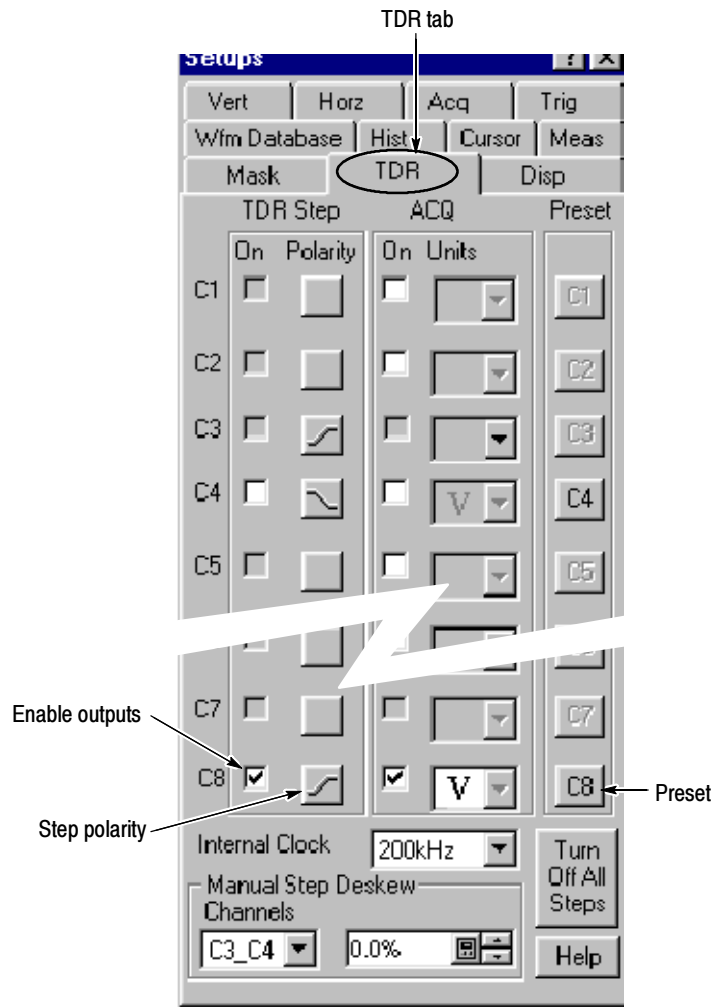

Figure 16: Setting the TDR parameters

- Set the **Preset** of Channel 8. The sampling module turns on a red light next to the **SELECT** channel button, indicating that TDR is activated for that channel.

TDR Preset sets Internal Clock in the Trigger menu, turns on the TDR Step in the TDR Setups menu, turns on the channel and selects the acquisition units in the TDR Setups menu, and sets the horizontal scale, position, and reference.

6. Turn off the display for Channels 3 and 8, then only Channel 4 is shown on the screen.
7. Set trigger mode to Internal Clock.
8. Adjust the oscilloscope horizontal and vertical position controls to display a signal similar to that shown in Figure 15.
9. Set the oscilloscope horizontal scale to 100 ps/div and center the waveform.
10. Use the oscilloscope measurement capability to display rise time. Increase the stability of the pulse-edge measurement by using averaging, if available. Rise time is measured from the 10% and 90% amplitude points on the waveform. Rise time can be measured using the automatic measurement capability of the TDS8200 series oscilloscopes. Record the system rise time as t_s . This value is used to calculate both the 5X and 25X probe rise times.

The following steps instruct you to assemble the test setup that includes the probe, as shown in Figure 17. The system and probe rise time (t_{s+p}) that you measure in step 17 is used to calculate the probe rise time (t_p) in step 18.

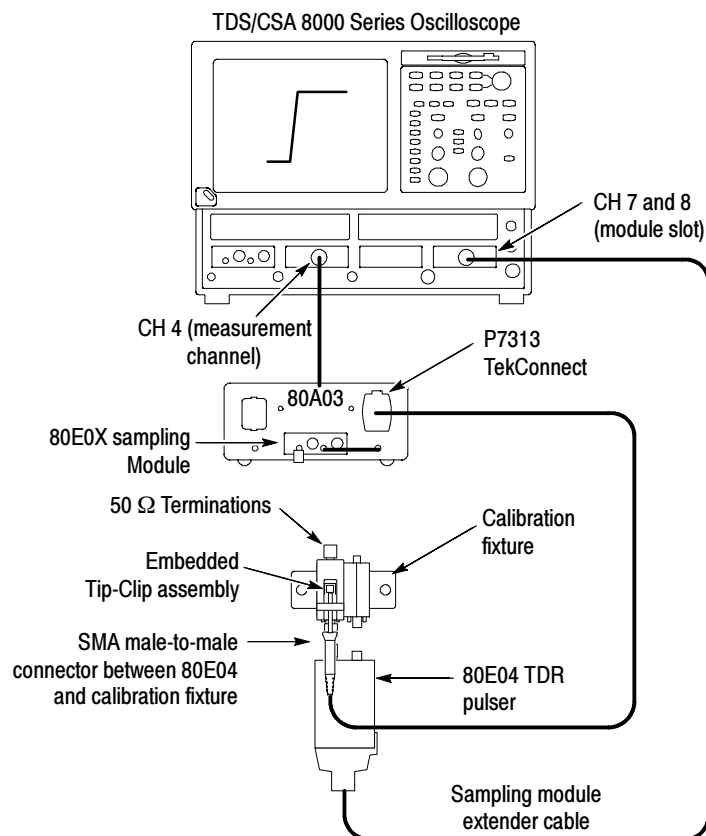

Figure 17: Test probe rise time setup

11. Connect the probe to the 80A03 TekConnect probe interface.
12. Check that an SMA 50 Ω termination included with the probe calibration fixture is connected to the open SMA input on the fixture.
13. Set the attenuation on the probe to 25X.
14. Connect the probe input to the probe calibration fixture as shown in Figure 14 on page 34. Check that the TDR function is still active.

The test setup should now be connected as shown in Figure 17.

15. Adjust the vertical scale to 50 mV/div, averaging on.
16. Expand the horizontal scale to help locate the step edge, then adjust the horizontal range to 100 ps/div while centering the edge view. For a more stable measurement display, turn averaging on.
17. Use the oscilloscope measurement capability to display rise time. Rise time is measured from the 10% and 90% amplitude points on the waveform. Record the rise time as t_{s+p} .

18. Calculate the probe rise time using the following formula:

$$t_p = \sqrt{t_{(s+p)}^2 - t_s^2}$$

19. Record the calculated probe rise time on the test record.

**Rise Time Check at 5X
Attenuation**

20. Set the attenuation on the probe to 5X.
21. Repeat steps 16 through 19 for the 5X attenuation setting.

Test Record

Probe Model/Serial Number: _____ Certificate Number: _____
 Temperature: _____ RH %: _____
 Date of Calibration: _____ Technician: _____

Performance test	Minimum	Results	Maximum
Output offset voltage 25X ± 3 mV (20 °C to 30 °C)	- 3 mV		+ 3 mV
5X ± 3 mV (20 °C to 30 °C)	- 3 mV		+ 3 mV
DC attenuation accuracy 25X	0.0392		0.0408
5X	0.196		0.204
Rise time 25X	N/A		40 ps
10-90 % 5X	N/A		40 ps

User Service

This section covers troubleshooting and probe maintenance.

Probe/Adapter/Oscilloscope Compatibility

The P7313 Differential Probe is designed to work with all TekConnect interface oscilloscopes and adapters. However, there may be some cases where probe features may not work properly.

Table 8: Differential probe compatibility issues

Symptom	Likely cause
P7313 Differential Probe does not work with an 80A03 TekConnect Probe Interface Adapter	The 80A03 Adapter requires firmware version V2.0 or above. The firmware version label is on the rear panel of the instrument. Contact Tektronix for information on updating the adapter firmware.
The LED on the 80A03 Adapter glows red, indicating an incompatible probe.	

Error Condition

The LEDs on the probe alert you to error or status conditions affecting the probe. If the probe LEDs flash or otherwise appear to be malfunctioning, an error condition may exist. Call your Tektronix representative for service.

When the probe is functioning correctly there is a quick flash of the LEDs on the probe just after connecting to the oscilloscope.

Replacement Parts

There are no user replaceable parts within the probe. Refer to your product user manual for a list of replaceable accessories for your probe.

If your probe does not meet the specifications tested in the Performance Verification, you can send the probe to Tektronix for repair. Follow the procedure on page 42 to prevent damage to the probe during shipping.

Preparation for Shipment

If the original packaging is unfit for use or not available, use the following packaging guidelines:

1. Use a corrugated cardboard shipping carton having inside dimensions at least one inch greater than the probe dimensions. The box should have a carton test strength of at least 200 pounds.
2. Put the probe into an antistatic bag or wrap to protect it from dampness.
3. Place the probe into the box and stabilize it with light packing material.
4. Seal the carton with shipping tape.
5. Refer to *Contacting Tektronix* at the front of the *P7313 12.5 GHz and P7380 8 GHz 5X/25X Differential Probes User Manual* for the shipping address.